

# Design of a DSP-based 24 bit Digital Audio Equalizer for Automotive Applications

*Alberto Bellini\**, *Eraldo Carpanoni\**, *Giacomo Frassi\**, *Monica Tesauri\*\**, *Emanuele Ugolotti\*\**

\* Dipartimento di Ing. dell'Informazione, University of Parma  
Parco Area delle Scienze, 181/A, I-43100, ITALY  
alberto.bellini@unipr.it

\*\* ASK Industries  
Via F.lli Cervi, 79, 42100 Reggio Emilia, ITALY

## ABSTRACT

The project deals with the design and realization of a dedicated board DSP-based for the processing of audio signals for automotive applications (DIGIcar). The I/O interface of the board is composed of two stereo inputs and two stereo outputs.

The prototype was realized in a four layer PCB with SMD components. The layers were designed in order to reduce high frequency effects of digital signals on analog audio signals.

The DIGIcar board was tested stand-alone with an Audio precision System 2022. Experiments were performed inside a car too, where the DIGIcar board was interfaced with a four channel power amplifier and connected between audio source and car loudspeakers. A development tool in MATLAB was exploited to synthesize the suitable equalizing filters given standard acoustics car measurements. Then the filters are stored in the board Flash EEPROM. A few options are available to tailor the equalizer for different cars. Listening tests and acoustic measurements show the effectiveness and the functionality of the designed board.

## 1. INTRODUCTION

Automotive engineering is an attractive field from any point of view, especially when dealing with accessories aimed at increasing comfort. As for hi-fi car audio systems the traditional low quality radio system is being moving to a sound system, even if the specific car compartment spatial composition makes sound reproduction a very hard task. Reverberations, reflections, echo, noise and vibrations are some of the issues to account for. A first step in the direction of increasing sound comfort is that of equalizing the acoustic pressure response in the frequency domain. To accomplish this task the inversion of the amplitude of the measured Sound Pressure Level (SPL) should be performed [1,2]. The main target of the equalization procedure is to increase sound comfort at the driver position, option which does not directly results in an

homogeneous quality in the whole car cockpit. However also spatial processing of audio source, like phase filters, delays between channels, and between rear and front loudspeaker has been found of large importance in order to increase sound quality reproduction [3,4]. Sound pre-processing results in a pleasant increase of sound quality, but often requires large computational power and high quality A/D and D/A converters, in order to prevent the introduction of quantization errors and additional conversion noise.

Every car features a peculiar conformation, which moreover is influenced by the number of occupants, by their position and also by environmental conditions, like running motor noise.

It is clear that common radio systems are insufficient to produce a pleasant sound reproduction. Audio Digital Processing Systems are becoming more and more wide spread in the consumer market, and they have entered car audio system too. They require peculiar hardware characteristics at a very low price, because of the target cost of a car acoustic equalizing system. From this rationale, the idea of designing a dedicated DSP board for the equalization of car cockpits was originated (DIGIcar).

## 2. HARDWARE DESIGN

Peculiar car characteristics, power supply levels, noise floor, and typical applications drew the technical specifications of DIGIcar. The target number of channels was four audio-in and four audio-out, in order to handle the left/right front/rear loudspeakers separately.

Therefore the technical specifications of the design were as follows: Bandwidth 20-20000 Hz, Sampling rate 48kHz, A/D conversion resolution 24 bit, 100 dB Signal-to-Noise Ratio, Low distortion, THD < 0.01%.

The DSP is a fixed point processor, since the target application is Digital Audio Processor for automotive sound system, where cost is a major concern.

The computational power of the adopted processor is 100 MIPS, i.e. around 500 FIR taps/sample/channel at 48kHz.

Therefore the following components were chosen: a TMS320VC5402 DSP [5], two stereo TMS320AD77C CODECs (integrated A/D and D/A up to 96 kHz sampling rate) [6], a watchdog, input and output interface circuitry based on discrete components and on TL074 opAmps, power supply circuits designed to be interfaced to a standard 12 V car battery. Moreover a Flash EEPROM is provided for stand-alone bootstrap. Input and output circuitry is specifically designed for anti-aliasing filters and to perform single-ended to double-ended signal conversion, as required by the CODECs. This conversion is needed since the companion amplifier uses single-ended signals. The opAmps are not biased in dual voltage supply, because of the peculiar application. A proper virtual ground at  $V_{batt}/2$  (half of the battery voltage) is generated by the power supply stage and is adopted for all discrete circuitry.

The four channels are processed by an analog circuitry, in order to convert single ended signal provided by the audio amplifier in double ended signals, consistent with the specification of the adopted CODEC, which is a TMS320AD77C. The CODEC features a 24 bit resolution and is operated at 48kHz. The output interface is again designed with opAmps to provide necessary filtering and conditioning, fig. 1.

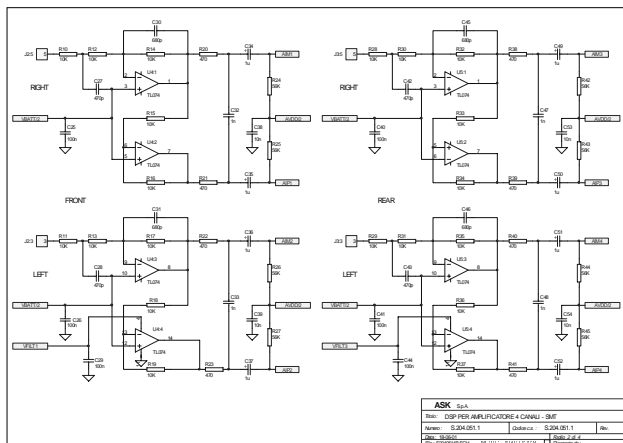

Figure 1 DIGIcar schematics analog audio input interface.

The CODECs are connected to the DSP exploiting the two DSP serial ports, fig. 2.

The power supply is obtained from the car battery operated by a circuitry based on LM317, which produces 3.3 Volt (for digital circuitry), 1.8 (core DSP supply), 12 Volt (opAmps power supply), with proper analog and digital ground management.

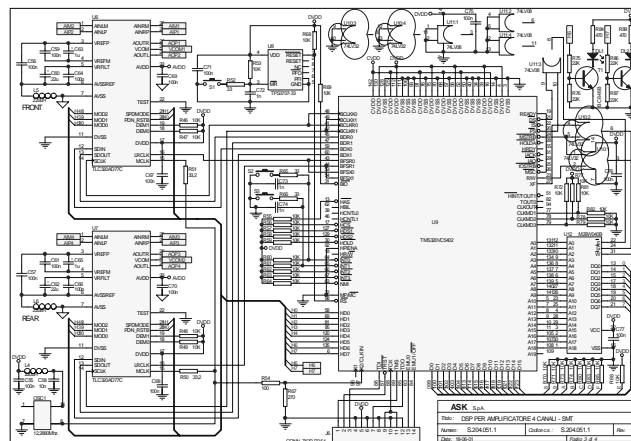

Figure 2 DIGIcar schematics, digital interface.

A serial port consistent with the IEEE 1149.1 (JTAG) standard is available too, which allows for both testing and programming of the DSP for debugging purposes through a host PC. Some switches and leds are added in the board for diagnostic purposes, and to provide user defined interrupts, which may be used for instance to change filter coefficients during acoustic system design.

Specific care was placed in the layout design of the input/output interface in order to obtain accurate symmetry for the four channels paths. Specifically the high frequency paths of the crystal are separated by audio signals, so that the glitches of the digital clock don't affect the quality of the signals. A separate analog and digital ground is provided, and the board is shielded with grounded planes.

The prototype board is reported in fig. 3. It was tested at first in a lab, programming the DSP through the JTAG TI emulator and Code Composer Studio. At first a simple talk-through program was used, which reproduces input signals to the output channels.

Audio Precision System 2022 was used to characterize the performances of DIGIcar, and the overall THD-N of the DIGIcar board, programmed as a talk-through system is around -85dB (medium quality opAmps are probably the main responsible for this level, which is fully consistent with car-audio high quality systems).



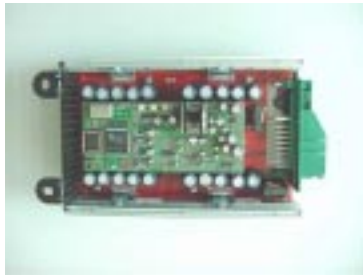

**Figure 3** DIGIcar prototype board (top) as a power amplifier daughter board (bottom).

### 3. CAR CHARACTERIZATION AND EXPERIMENTAL SET-UP

The DIGIcar board is capable of processing the four channels separately. The performances when four different FIR are processed are up to 500 taps for channel at a sampling rate of 48kHz.

As an example four filters were programmed and tested in the lab. In this case the code is hand written in assembly code, and four FIR filters are implemented with the MAC instruction in four Interrupt Service Routines, synchronized by the Frame Sync signal of the CODEC and the inner TIMER.

The synthesis of the suitable filter coefficients for the digital equalizers requires at first car acoustic characterization, and then an automatic procedure to compute and store filter coefficients (fig. 4).

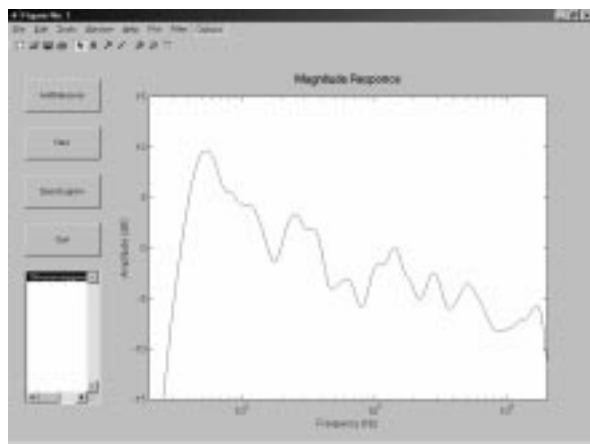

**Figure 4** Software development system for equalizing filter synthesis.

Two software architectures are available. The former implements four FIR filters (one for each channel), while the latter four IIR filters. The former option requires the computation of the filters taps, given car acoustic measurements. The latter option is usually employed, implementing 5-bands or 7-bands parametric equalizer, mimicking common acoustic equalizer.

FIR filter taps computation is automatically performed starting on car acoustic measures, performed with a Bruel&Kjaer 4192L microphone separately for the four channels (front-left, front-right, rear-left, rear-right), digital acquisition is made with a Layla sound card by ECHO. A dummy head placed in the driver position is used to this aim. Several characteristics can be obtained in this way. The frequency spectrum of the car Sound Pressure Level can be obtained with MLS or sine-sweep measurements [7]. Then the four channel SPL can be inverted and synthesized with four minimum phase FIRs. Specifically the frequency response amplitude is processed so that the obtained spectrum convolved with the car acoustic measurements result in a target “comfort” curve. The phase of the measured frequency response is unchanged, in the sense that only linear-phase FIR are used. The “comfort” curve is not necessarily a flat curve, but it depends on the specific car physical conformation or target customers.

Another option is the measurements of the car AQT [8], which provides a frequency spectrum referring to the signal dynamics and not to steady state measurements. This allow to characterize more accurately how the car inside reacts acoustically to music. Then as before the AQT frequency response is inverted and implemented with minimum phase FIR filters.

### 4. EXPERIMENTAL RESULTS

Then as a typical example application the DIGIcar board was validated with a car cockpit acoustic equalization.

The filter obtained in one of the three methods described in section 3 (IIR parametric filter, inverse-SPL FIR, inverse-AQT FIR) are convolved with the stereo audio source and sent to a 40 W 4-channel amplifier that drives the car loudspeakers.

An Opel Corsa was used as the test car. It featured a standard loudspeaker system, with four channels.

Four different 385 FIR filters were implemented on each channel of DIGIcar. Each filter synthesizes the inverse SPL of each channel, or the inverse AQT of each channel. Another option is the use of 5-band IIR filter, where the tuning is made on the basis of listening tests.

For listening tests listeners (seated in the driver position) can blindly change between the three different equalizations and the no-equalization condition.

In the following experiments are reported. Fig. 5 shows the SPL of the Front-Left channel, measured with MLS de-convolution. Fig. 6 show the electric measurements of DIGIcar Front-Left channel, an Audio Precision System 2020 was used to this aim.

Fig. 7 shows a comparative spectrum analysis, addressing the effect of equalization. The two dashed lines refer to SPL-inverse and AQT-inverse equalization.

Standard SPL measurements are reported. Fig. 8 shows the same comparative analysis reporting AQT measurements.

Listening tests show how the equalized car is mostly preferred, because of its increased sound image.

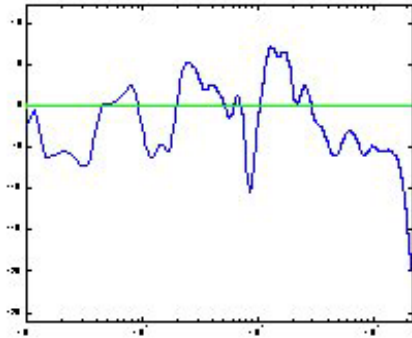

**Figure 5** Opel Corsa cockpit acoustic measurements (Front-Left channel SPL).

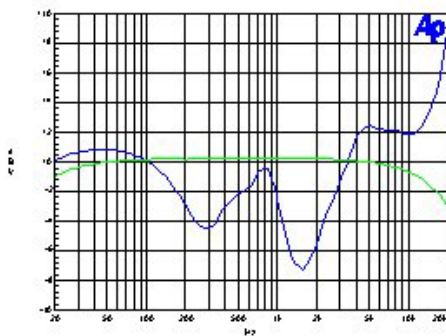

**Figure 6** DIGIcar FL channel programmed to implement a 385 FIR filter, synthesizing the AQT inverse response.

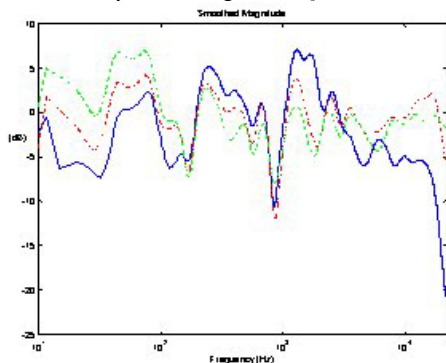
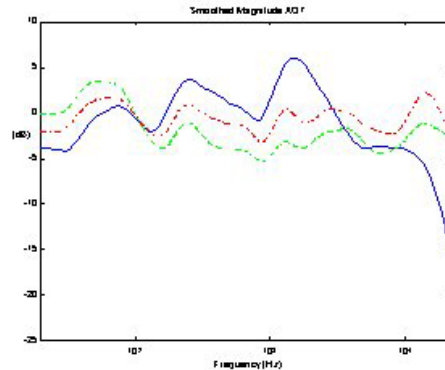

**Figure 7** SPL measurements of Opel Corsa Front-Left channel, with DIGIcar equalization (dashed lines) and without (solid line).

### CONCLUSIONS

A DSP-based four analog-in four analog-out board, tailored for car-audio acoustic equalization system was designed, realized in 4 layers and experimentally validated

in lab tests (with Audio precision 2022 system) and in commercial cars. Experiments are consistent with typical requirements of car audio systems.



**Figure 8** AQT measurements of Opel Corsa Front-Left, with DIGIcar equalization (dashed lines) and without (solid line).

Three different equalizing structures are available: a 5-band IIR, SPL-inverse FIR, and AQT-inverse FIR. They can be chosen at testing time depending on the specific car acoustics conformation.

Both subjective and objective tests show the effectiveness and the functionality of the designed board.

### REFERENCES

- [1] G. Cibelli, A. Bellini, E. Ugolotti, A. Farina, C. Morandi “Experimental validation of loudspeaker equalization inside car cockpits”, preprint #4898 AES 106th convention, Munich, May 1999.
- [2] S.T. Neely, J.B. Allen, “Invertibility of a room impulse response”, Journal of the Audio Engineering Society, May 1979, vol. 66, pp. 165-169.
- [3] A. Bellini, A. Cannizzaro, G. Cibelli, E. Ugolotti, A. Farina, C. Morandi, “Experimental validation of stereo dipole systems inside car cockpits”, in Proc. of ICSPAT’99, Orlando, FL, November 1999.
- [4] Ole Kirkeby and Philip A. Nelson, “Local sound field reproduction using two closely spaced loudspeakers”, Journal Acoustic Society of America, vol. 104, no. 4, October 1998, pp. 1973—1981.
- [5] Texas Instruments, *TMS320VC5402 Fixed-Point Digital Signal Processor*. 1998
- [6] Texas Instruments, *TLC320AD77C 24-Bit 96 KHz Stereo Audio Codec*. 1999.
- [7] A. Farina, E. Ugolotti, Automatic Measurement System For Car Audio Application. Pre-print of the 104<sup>th</sup> AES Convention, 15-20 May 1998
- [8] A. Farina, G. Cibelli, A. Bellini, “AQT – A New Objective Measurement of The Acoustical Quality of Sound Reproduction In Small Compartments”, preprints of AES 110, Amsterdam, Olanda, May 2001